

T100 microturbine system

Technical description

T100 Natural Gas



Turbec

D 14127-03 Version 3 09/12/29

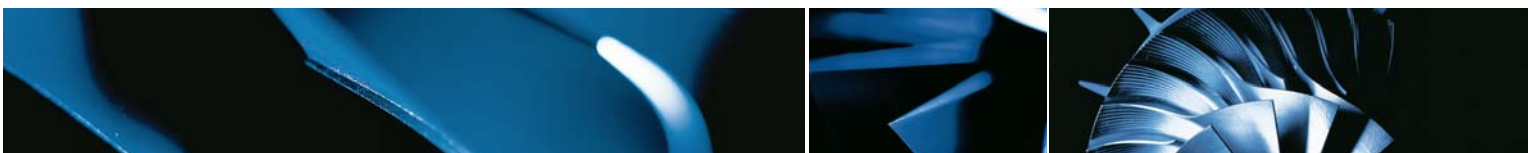

Contents

1. T100 Power module.....	3
1.1 Product description Power Module...	3
1.2 Performance for T100 P	6
1.3 Scope of supply and Terminal points for T100 P	7
1.4 Installation of T100 P.....	7
1.5 CE compliance	9
1.6 Maintenance concept.....	9
1.7 Operation of T100 P.....	10
2. T100 Power and Heat	11
2.1 Product description	11
2.2 Performance for T100 PH	12
2.3 Scope of supply and Terminal points for T100 PH	13
2.4 Installation of T100 PH	14
2.5 CE compliance	15
2.6 Maintenance concept.....	15
2.7 Operation of T100 PH	15
3 Options	16

T100 module description

The Turbec T100 microturbine system is a modular system designed to generate power and heat with high efficiency and low emissions. In addition the T100 has several complementary modules which can be used in a large number of applications.

1. T100 Power



The Turbec T100 Power (T100 P) produces electrical power. It can be used in processes where the hot exhaust gases are used directly for drying, cooling etc, or power production only. The Turbec T100 P uses a high speed generator to produce electricity. The compressor and the turbine are placed on the same shaft as the generator. An exhaust gas recuperator is connected to the microturbine to improve the electrical efficiency. The scope of supply also includes an induced draft.

Introduction

2. T100 Power and Heat

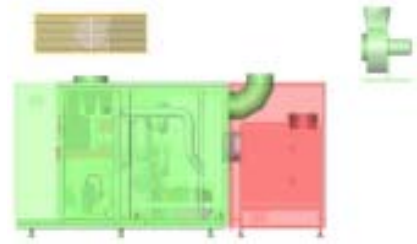

The T100 Power and Heat unit (T100 PH) is the T100 Power module combined with an exhaust gas heat exchanger. This combination allows the T100 to produce combined heat and power achieving very high overall efficiencies. The hot gases leaving the microturbine are in this case used to produce hot water. The overall efficiency of the microturbine will in this way be highly improved.

3. Options

The T100 microturbine system offers the following options:

- External pre-filter
- Outdoor installation
- By-pass of heat exchanger
- Load following
- Removal of fuel booster
- Additional relay protection
- Log file decoder
- GSM modem
- Weekly scheduler
- Alternative fuels

1.1 Product description for T100 Power

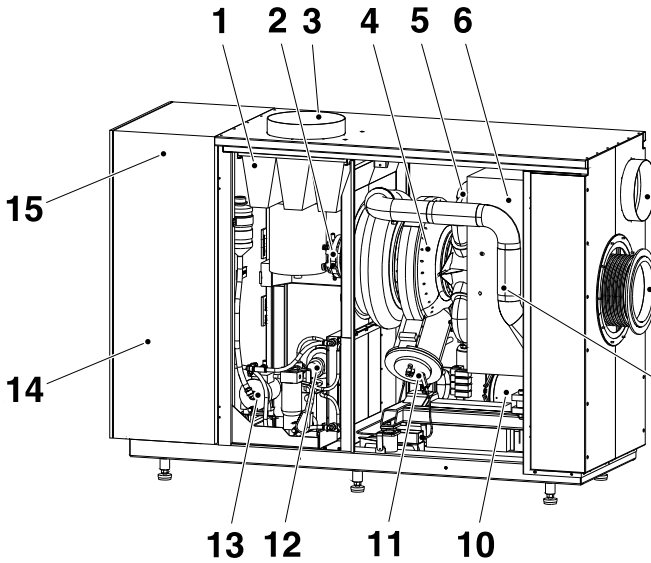

- 1. Air filter
- 2. Generator
- 3. Air inlet
- 4. Gas turbine engine
- 5. Pipe from recuperator
- 6. Recuperator
- 7. Ventilation air outlet
- 8. Exhaust gas outlet
- 9. Pipe to recuperator
- 10. Gas compressor
- 11. Combustion chamber
- 12. Oil pump
- 13. Cooling water pump
- 14. Power electronics
- 15. Control system

1.1.1 Main components for T100 P

The Turbec T100 P consists of the following main parts:

- Gas turbine engine
- Electrical generator
- Electrical system
- Supervision and control system

Gas turbine engine

The gas turbine is a single shaft engine. The main components are:

- Housing
- Compressor
- Recuperator
- Combustion chamber
- Turbine

Housing

The electrical generator and the rotating components of the gas turbine are mounted on the same shaft. The parts are mounted in the same housing.

Compressor

The Turbec T100 uses a radial centrifugal compressor to compress ambient air. The pressure ratio is about 4.5:1. The compressor is mounted on the same shaft as the turbine and the electrical generator.

Recuperator

The electrical efficiency of the gas turbine is increased with a recuperator. The recuperator is a gas-to-air heat exchanger attached to the microturbine. The heat is exchanged from the hot exhaust gases to the compressed air that is fed to the combustion chamber.

Combustion chamber

The preheated compressed air is mixed with the fuel. During start up an electrical igniter in the combustion chamber ignites the mixture. The combustion chamber is of lean pre-mix emission type, achieving exhaust gases with low emissions of NO_x, CO and unburned hydrocarbons.

Turbine

The turbine drives the compressor and the generator. When the combustion gases leave the combustion chamber the temperature is approx. 950°C (1 742°F) and pressure is approximately 4.5 bar (65 psi). As the combustion gases expand through the turbine the pressure decreases to nearly atmospheric pressure and the temperature drops to approx. 650°C (1 202°F).

Electrical generator

The electric power is generated by a permanent magnet rotating at high speed. The generator rotor is suspended by two bearings, one on each side of a permanent magnet. Further more, the generator acts as an electric starter. The generator is water-cooled, and designed for high conversion efficiency.

Electrical system

The high frequency AC power from the generator is rectified and converted to the desired grid voltage and net frequency. The AC power is rectified and converted to the electrical grid frequency. A line filter and a transformer stabilizes and smoothes the AC output. During start-up, power is taken from the grid and used for electric start of the gas turbine.

Supervision and control system

The Turbec T100 is controlled and supervised by an automatic control system that resides at the Power Module Controller (PMC) so the unit needs no personal attendance under normal operation. In case of grid distortion or system failure the system automatically shuts down and the fault is logged by the PMC. The PMC controls and supervises the start-up, running and rollout.

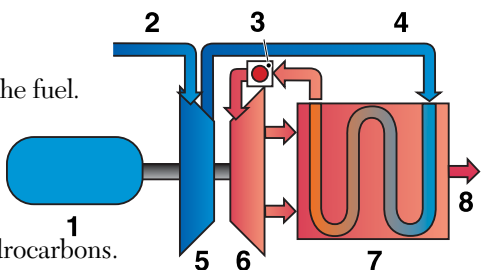

- 1. Generator
- 2. Inlet air
- 3. Combustion chamber
- 4. Air to recuperator
- 5. Compressor
- 6. Turbine
- 7. Recuperator
- 8. Exhaust gases

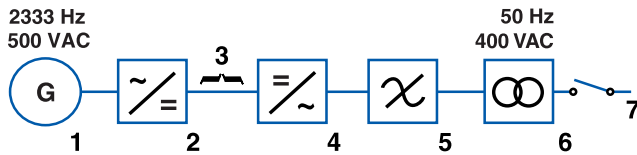

- | | |
|------------------------------|----------------|
| 1. Generator | 5. Line filter |
| 2. Rectifier/Start converter | 6. Transformer |
| 3. DC bus | 7. Main switch |
| 4. Converter | |

For this purpose a set of variables are monitored through sensors that measure:

- Turbine outlet temperature
- Power output
- Oil and water temperature
- Vibrations

In case of faults, the PMC executes one of the following actions:

- Normal stop
- Emergency shut down

The fault is presented on the display at the operator's panel to guide operating personell.

1.1.2 Auxiliary systems for T100 P

The auxiliary systems in the Power module are divided into the following systems:

- Lubrication system
- Cooling system
- Air intake and ventilation system
- Fuel gas system including fuel booster
- Buffer air system

Lubrication system

The purpose of the system is to lubricate the squeezed film bearings on the rotor shaft. The system consists of a closed piping system and an oil tank with an oil pump placed within the enclosure. A motor-driven pump circulates the lubrication oil. The lubrication oil circulates from the bearings to an oil-to-air cooler and is cooled below 50°C (122°F). The PMC monitors oil pressure and oil temperature before and after the bearings to obtain a reliable and continuous operation of the microturbine unit.

Cooling system

The generator is cooled with a separate closed cooling water system placed within the enclosure.

Air intake and ventilation system

A T100 installed indoors draws ambient air from an outdoor intake. As the air reaches the T100, the flow is divided into two partial flows. The main flow acts as combustion air in the microturbine. The secondary flow ventilates the excess heat out from the Power module. An induced draft fan placed on the outside wall creates a negative pressure inside the enclosure, for safety reasons and for cooling of the engine. The ventilation air enters the T100 through an air duct. There are two air filters in the T100 system, the pre filter and fine filter. The pre filter (optional supply) is placed close to the outdoor intake of the air and the fine filter is placed close to compressor within the enclosure for filtering the combustion air.

Fuel gas system

The fuel gas system consists of a fuel control system and a fuel booster. It is necessary to use a fuel booster to raise the gas pressure when it is below 6 bar (g) (87 psig). The fuel gas is taken into the fuel booster and discharged to the fuel control system. In the combustion chamber, the fuel is mixed with preheated compressed air.

Buffer air system

The gas turbine compressor supplies the buffer air system with air to block the lubrication oil from entering the gas turbine engine and the generator. After the sealings, the air passes through an oil separator in which the oil mist is separated from the air and collected in the lubrication oil tank.

1.1.3 Technical data for T100 P

General identification

Type:	Microturbine
Manufacturer:	Turbec Spa, Italy
Model:	T100 P
Application:	Power generation
Usage:	Indoors (Option Outdoors)
Dimensions	
Width:	900 mm
Height:	1 810 mm
Length:	2 770 mm
Weight:	2 250 kg
Fuel:	Natural gas
Ambient inlet temperature:	-25°C to 40°C (-13°F to 104°F)
Ambient inlet humidity:	< 100 %
Surrounding air temperature:	-10°C to 40°C (14°F to 104°F)
Surrounding humidity:	< 100 %

Gas turbine

Compressor type:	Centrifugal
Turbine type:	Radial
Type of combustion chamber:	Lean pre-mix
Number of combustion chamber:	1
Pressure in combustion chamber:	4.5 bar (a) (65 psia)
Turbine inlet temperature:	950°C (1 742°F)
Number of shaft:	1
Nominal speed:	70000 rpm
Consumption of lubrication oil:	<3 litre/6 000 h operation (<0.8 gal/6 000 h operation)

Electrical data

Frequency output:	50 Hz
Max apparent power:	120 kVA
Max allowed mains frequency variation:	±5%
Max allowed mains voltage variation:	±10%
Adjustable power factor:	0.80 leading to 0.80 lagging*
Nominal voltage output:	400/230 V AC, 3 phases
Start up voltage:	400 V AC, 50 Hz
Start up power:	max 15 kW
Rated current:	173 A
Harmonic current	
Max total distortion:	5% related to rated current
Max single distortion:	3% related to rated current

Output circuit: 4 wire connection
 Protection circuit containing:
 Thermal overload protection:
 Over/under frequency protection**
 Short circuit current protection
 Over/under voltage protection**

* may be limited by max apparent power
 ** located in power electronics. For machine protection only

Gas requirements

Pressure min/max without fuel booster:	6/7 bar (g) (87/116 psig)
Pressure min/max with fuel booster:	0.02/1.0 bar (g) (0.3/14.5 psig)
Temperature min/max:	0°C/60°C (32°F/140°F)
Wobbe index:	43-55 MJ/m ³ (1154-1476 Btu/scf)
Maximum content in natural gas:	H ₂ O 150 ppm/v H ₂ S 5 mg/m ³
Fuel gas flow:	Depending on gas composition
Example at nominal load,100 kW:	
Fuel gas LHV:	39 MJ/m ³ (1047 Btu/scf)
Volume flow:	31 m ³ /h (1095 scf/h)

*Definition of Wobbe index: $W = \frac{HHV}{\sqrt{\frac{\rho_{gas}}{\rho_{air}}}}$

1.1.4 Principal diagram for T100 P

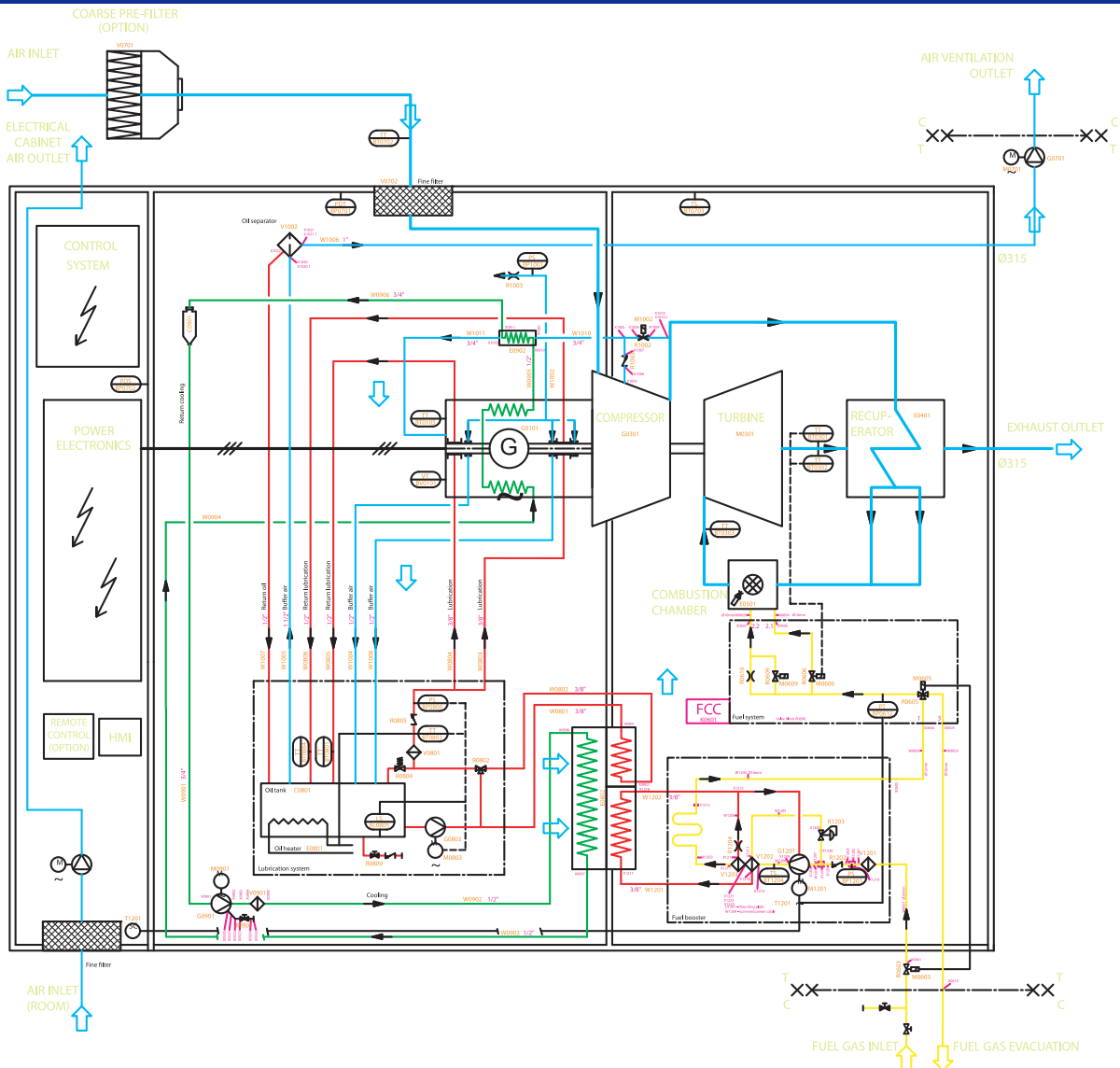

1.2 Performance for T100 P

Performance notes

The performance data includes the T100 auxiliary consumption powered by T100, i.e. cooling water pump, fuel compressor, oil pump, induced draft fan. The data is based on the following conditions for new and clean equipment operating at ISO standard conditions:

Site elevation:	0 m above sea level
Ambient temperature:	15°C (59°F)
Relative humidity:	60%
Pressure drop to air inlet flange:	0 Pa (0 psi)
Pressure drop from exhaust gas flange:	0 Pa (0 psi)
Fuel type:	Natural gas
Data for LHV:	39 MJ/m ³ (1047 Btu/scf)
Fuel gas pressure:	Low pressure gas source (0.02 - 1.0 bar (g)) (0.3 - 14.5 psig)

1.2.1 Performance data

Electrical output:	100 kW (±3)
Electrical efficiency:	30 % (±1)
Fuel consumption:	333 kW (1 137 000 Btu/h)
Exhaust gas flow:	0.80 kg/s (6 350 lb/h)
Exhaust gas temperature:	270°C (518°F)
Noise level:	72.3 dBA at 1 meter (3.3 ft)
Nominal volumetric exhaust gas emissions at 15% O ₂ , 100% load; at 15°C air temperature.	
NO _x :	< 6 ppm/v = 12.8 mg/MJ fuel
CO:	< 6 ppm/v = 7.2 mg/MJ fuel
Maximum volumetric exhaust gas emissions at 15% O ₂ , 100% load; at 15°C air temperature.	
NO _x :	< 15 ppm/v = 32 mg/MJ fuel
CO:	< 15 ppm/v = 18 mg/MJ fuel

Part load performance

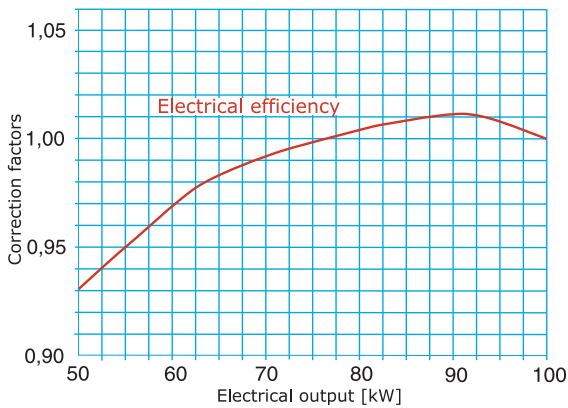

1.2.2 Air inlet temperature influence

Chart presenting air inlet temperatures influence on T100 P microturbine performance based on low pressure gas sources 0.02 bar (g) (0.3 psig).

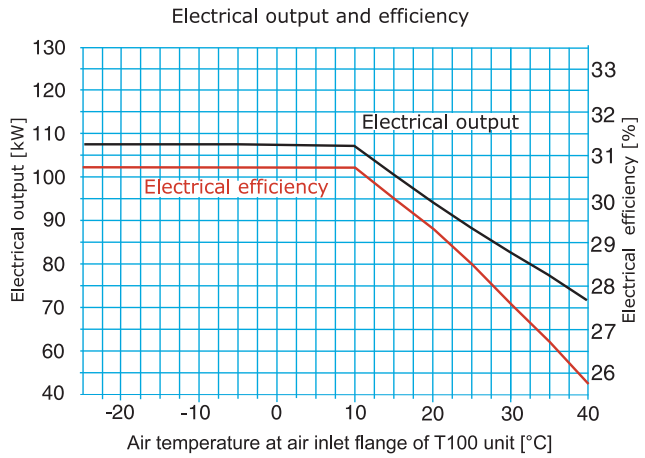

For high pressure gas source add approximately 5 kW electrical output and 1.5 % points electrical efficiency.

1.2.3 Corrections of performance

Charts presenting corrections of performance at different loads, site elevations, inlet pressure drop and outlet pressure drop.

Performance at different site elevations

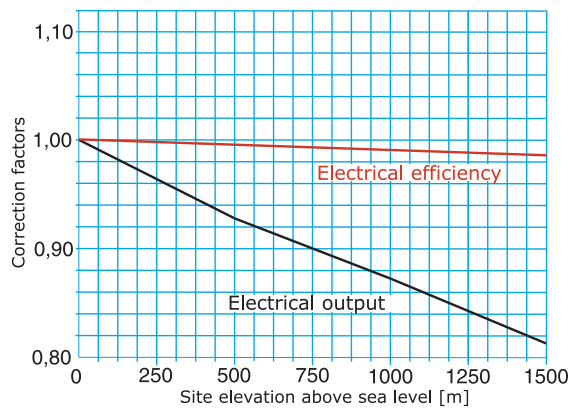

Performance at different inlet pressure drop

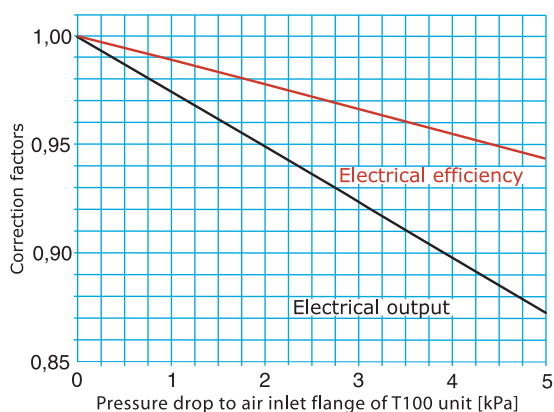

Performance at different exhaust pressure drop

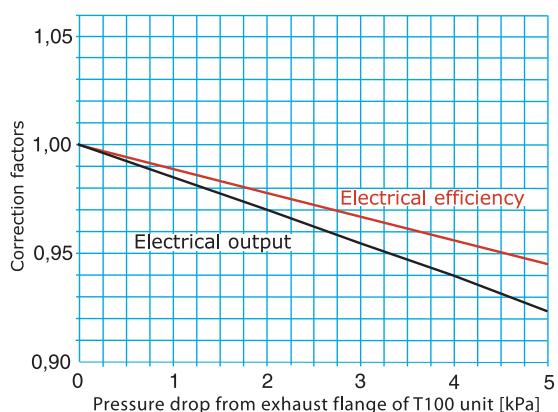

1.3 Scope of supply and Terminal points for T100 P

1.3.1 Scope of supply

The delivery covers a complete Power module, ready for installation at terminal points below. The main parts of the scope of supply are as follows:

- Microturbine unit including turbine, compressor, generator and recuperator
- Fuel system including fuel booster
- Closed cooling water system for generator and electrical system
- Closed lubrication system for gas turbine
- Enclosure for insulation protection of heat and noise
- Induced draft fan for ventilation of the enclosure, delivered as a separate item
- Frequency and voltage converter for the supply of 400 VAC, 3 phase, 50 Hz
- High performance electrical output filtering
- Circuit breaker
- Starting system including synchronizer
- Control panel with digital LCD display
- RMC, Remote control system with modem
- Documentation:
 - Installation manual
 - Operator's manual
 - Maintenance manual
 - Electrical manual

1.3.2 Terminal points

The following terminal points apply to the scope of delivery of a Power module of this proposal:

- Connection for air inlet, located at the T100 enclosure roof
- Exhaust gas outlet, located at the T100 enclosure wall
- Fuel gas inlet, located at the T100 enclosure wall
- Pre filter air inlet, located at the T100 enclosure roof
- Fuel gas evacuation system outlet, located at the T100 enclosure wall
- Outlet connection of the ventilation air system, located at the T100 enclosure wall
- Electrical connection at the T100 enclosure wall and connection to ventilation fan, Ethernet cable or phone line for RMC connection.

- | |
|---|
| <p>A. Exhaust gas outlet
 B. Ventilation outlet without duct
 C. (Ventilation outlet with duct)
 D. Fuel gas inlet
 E. Fuel gas evacuation
 F. Prefiltered air inlet
 G. Electrical cables
 H. Grid cable</p> |
|---|

1.4 Installation of T100 P

1.4.1 Layout and terminal points

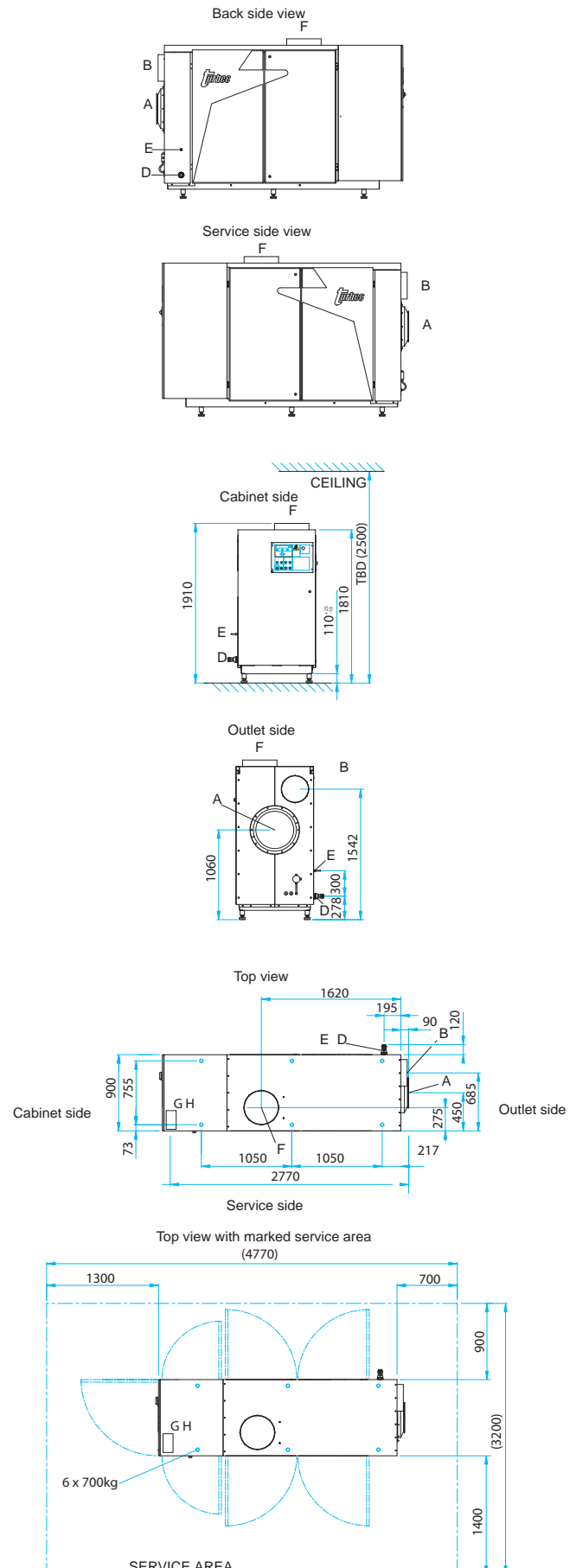

1.4.2 Installation guidelines for T100 P

Combustion and ventilation air inlet pipe installation

Dimension of connection:	Ø400 mm (15.75")
Connection type:	Twisted tube galvanized
Max air flow at 15°C (59°F):	1.69 kg/s (=1,38 m ³ /s); 3.73 lb/s (48.7 ft ³ /s)
Max air pressure drop from pipe inlet to T100 unit*:	< 180 Pa (0.72" W.C.)
Max air pressure drop from pipe inlet to T100 unit with worn filter*:	< 320 Pa (1.29" W.C.)

* The example corresponds to 10 m pipe, Ø400 mm (15.75") and two 90° elbows

Installation on indoor site:

Pipe, Ø400 mm (15.75"), to be installed from ambient air intake to the interface of T100 unit. If possible mount through a northern wall.

Pre-filter mounted in ambient air intake, size about 1200 x 800 mm (3.94 x 2.62 ft).

A pre-filter is mandatory. It is available as an option from Turbec, but it can be purchased from a local supplier if the requirements are observed:

	3.73 lb/s (=48.7 ft ³ /s)
Max pressure drop for a clean filter:	< 50 Pa (0.20"W.C.)
Max pressure drop for a worn filter:	< 190 Pa (0.76"W.C.)

Make sure the filter type uses an intake screen, e. g. use two standard size cases with the dimensions: 610 x 610 mm (2.00 x 2.00 ft).

The pipe shall be fitted with 50 mm (2") condense insulation.

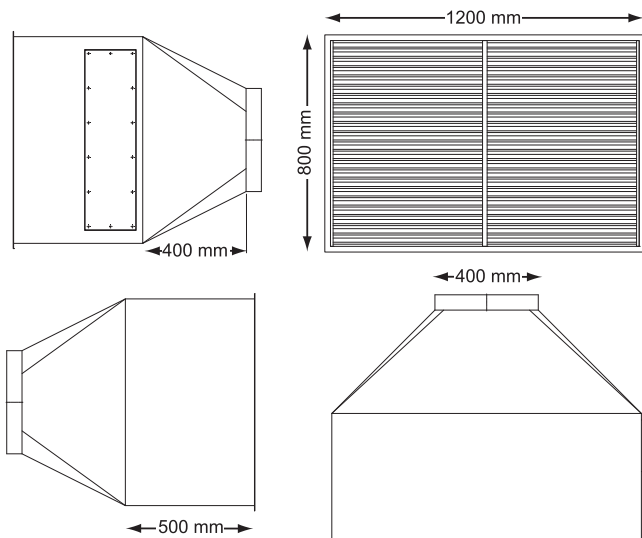

Ventilation outlet installation

Dimension of connection:	Ø315 mm (12.4")
Material of connection:	Twisted tube
Max air flow:	0.90 kg/s (=0.80 m ³ /s); 1.98 lb/s (28.2 ft ³ /s)

Installation on site:

The pipe, Ø315 mm (12.4"), is to be installed between T100 unit and the ventilation system exit.

An induced draft fan is mounted outdoors to the ambient air outlet. The ventilation outlet has to be designed so that rain and snow cannot enter the T100 unit.

Exhaust gas outlet installation

Type of connection:	Flange for V-clamp, Ø360 mm (14.2")
Material of connection:	Black steel
Max exhaust gas flow:	0.87 kg/s (1.92 lb/s)
Max temperature:	325°C (612°F)

Clamp and sealing are supplied by Turbec.

Installation on site:

Pipe (Ø315 mm) to be installed from the T100 P unit to a chimney, material according to national standard.

Design the exhaust gas installation so the pressure drop is kept low. An expansion bellow has to be installed after the T100 P interface. The chimney outlet has to be designed so that rain and snow cannot enter the T100 P unit.

Electrical installation

Cable overview

This cable overview shows general information about the most important electrical cables are to be connected to the T100 for power generation output. The T100 customer connection terminal is prepared for optional signal connections. Exactly what signals needed depend on the site and the functions being used. For further details, see the installation manual.

Cable	Connection point	Usage
Power cables	Electrical grid	Power generation
Phone line	The national telecommunication system	Remote control via modem

The T100 is to be connected to a system with the rated phase to phase voltage given in section 1.1.3 Technical data for T100 P - Electrical data. The neutral is never used by the standard grid parallel T100 and its connection is therefore not needed.

As shown in figure, it is required that the star point of the Y connected three phase grid system is to be connected to ground. This ground can then be supplied to the T100, given as alternative 1 in the figure ↓. Alternative 2 shows how the T100 is connected to a 4-wire connection system where the protected earth wire (PE) and the neutral wire (N) are combined in a PEN-wire. In alternative 3, a safety ground to the T100 is locally created.

The standard T100 electrical system is designed to break a short circuit current up to 35 kA provided from the grid to the T100. The short circuit current capability of the grid must be checked before installation of the T100. If it exceeds the given values, Turbec must be contacted.

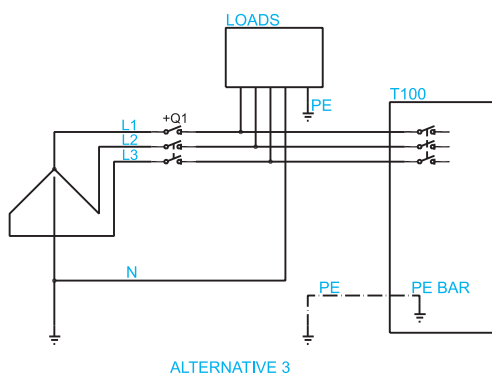
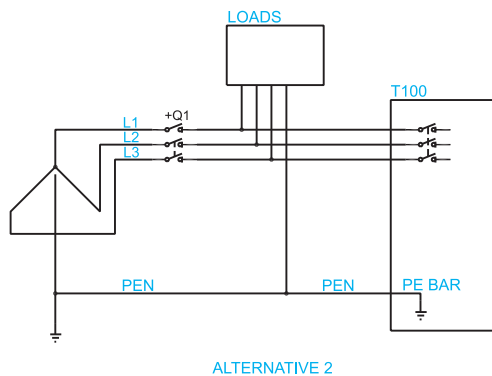
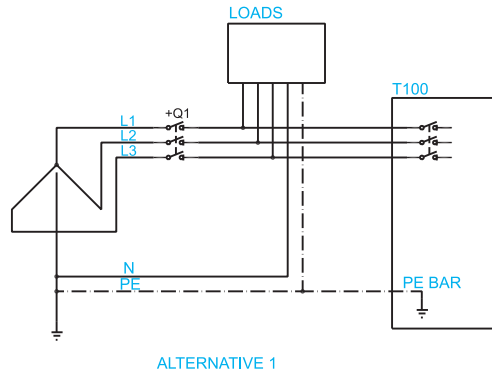

Protections and emergency stop systems.

The T100 supply several safety systems that disconnect the T100 from the grid in case of a fault.

The grid cables are connected to the T100 main breaker, which is a manually operated circuit breaker. In case of work on the power connection to the T100 this must be opened and locked to prevent the T100 from generating power to the grid.

The circuit breaker also gives a thermal overcurrent protection and a short circuit protection.

Between the breaker and the power electronics, a transformer and a contactor is connected. The contactor is opened by either one of the internal protections (machine or power electronics controls), an external signal or any of the emergency stop buttons.

The T100 is prepared for two different relay protection alternatives:

- An optional relay protection can be mounted in the T100 cabinet. In case of a trip, this also opens the main contactor using the hard wire loop.

- A protection external to the T100. Any protection, accepted by the utility, which supplies a potential free open/closed signal can be used in the installation. The potential free signal is fed to the T100 and will with hardware open the main contactor.

A skilled and experienced electrician may recommend an alternative installation.

The electrical system is subject to several site-specific demands. Those are both technical and regulatory, and have to be adapted to the standards and regulations in each country.

1.4.3 Natural gas installation

Type of connection:	thread connection, 1 1/4", female
Natural gas pressure:	0.02 - 1.0 bar (g) (0.3 - 14.5 psig)
Fuel gas evacuation outlet:	Ø10/8 mm

Installation on site:

The natural gas piping is routed from the low-pressure system to the T100 microturbine unit.

The T100 microturbine unit is equipped with the fuel gas evacuation. There has to be a 10-mm pipe routed from the unit to ambient.

Note:

The complete fuel gas installation is subject to local regulations and may therefore need to be adapted to the national standards and regulations.

1.5 CE compliance

This equipment complies with the basic health and safety regulations of the European Economic Area (EEA). The T100 unit follows these directives:

Machinery Directive 98/37/EC

Noise Directive 2000/14/EC

Electromagnetic Compatibility Directive 2004/108/EC

Low Voltage Directive 2006/95/EC



1.6 Maintenance concept

The T100 maintenance concept is built on the following cornerstones:

- Remote T100 monitoring by Remote Monitoring and Control (RMC)
- Built-in functions for operating condition based maintenance
- A well defined T100 preventive maintenance program
- Support and maintenance coverage

The simple design of the T100 provides for a durable and reliable operation for many years. Design and selection of components are made to achieve a maintenance free unit to the maximum extent possible.

The T100 is designed for easy access to the few maintenance demanding items. Fault diagnostics is performed by the RMC system and easy on site communication with the unit limiting time for fault finding and corrective measures. The modular T100 design requires no special tooling or lifting devices during normal operation and maintenance.

Continuous remote unit monitoring by RMC (Remote Monitoring and Control)

Through use of the RMC system, monitoring of operation, unit status, trend analysis as well as trouble shooting is continuously performed. The RMC system in these cases provides information for long term trend analysis as well as high sample rate information for event analysis and trouble shooting support.

Corrective measures always begin with facilitating the RMC system, which significantly reduces outage time due to unscheduled events and makes expert support available on short notice.

Built-in functions for operating condition based maintenance

The T100 unit is equipped with built-in functions for condition based maintenance such as filter exchanges as well as automatic warnings and alarms for pertinent situations and events.

Maintenance program

The T100 experience based preventive maintenance program includes inspections and replacement of life limited components ensuring a trouble free operation. The unit design lifetime is 60 000 h with a planned overhaul after 30 000 h, and limited inspection/maintenance activities in between. Details about the inspection/maintenance activities and intervals are found in the applicable maintenance plan.

Support and maintenance coverage

The basic contractual maintenance concept is built on service partner coverage. Turbec guarantees the supply of spare parts, technical support and training, and the local service partner provides rapid on-site assistance. Turbec support and maintenance infrastructure is continuously improved in order to minimize any outage times.

1.7 Operation of T100 P

Start

The starting system is fully automatic and can be engaged by a push button on the local control panel or via the remote control system, an external Building Management System (BMS), a MODBUS communication or automatically via a weekly scheduler. The start up sequence includes starting, evacuation, ventilation and synchronization to the grid.

Normal start-up procedure will bring a cold T100 microturbine into 80% load in 10 minutes, and 100%

load in 20 minutes. During start up the generator operates in motoring mode, using electrical power from the grid. After 60 seconds of ventilation the combustor is ignited, the generator speeds up and the power generation is started. The enclosure, the engine and the exhaust pipe are completely purged before ignition.

Restart time after shutdown will be less than 5 minutes, provided that the engine is still warm. The T100 is equipped with a function for automatic restart, activated when the stop was caused by external disturbances or minor faults. A short interruption or disturbance on the electrical grid will not cause a T100 stop. Instead it will disconnect from the grid by opening the main contactor, keep the T100 running supplying the T100 auxiliaries and reconnect when the grid returns.

Operating Mode

The T100 microturbine operates mainly on standard speed regulation, which results in a high efficiency in part load operation.

Control System

The T100 unit can be controlled in seven ways:

- Locally by the Operators panel
- Through hard-wired BMS
- Through a pc with a web browser connected to the T100 unit via Ethernet cable
- Through a pc with a web browser connected via a telephone modem (normal or GSM(option)) to the T100 control system
- Via Modbus interface, RS232
- Automatically with a weekly scheduler (option), allow starts and stops according to a pre-defined schedule
- Depending on externally measured data, such as air temperatures or electrical power (the option load following)

Examples of operational control commands:

- Start and Stop of the machine, including a manual emergency stop
- Change set points for electrical active and reactive power demand
- Do a fault reset

Examples of data that can be monitored through the control system:

- Operational mode: stopped, starting, running, and stopping
- Measured data: electrical power output, (net electrical power as option), produced electrical energy, running hours, etc.
- Warnings and faults with description

Copyright © 2009 Turbec Spa
All rights reserved. No parts of this document may be reproduced or copied in any form or by any means without written permission from Turbec Spa. The material and data in this document may be changed without further notice, reservations for misprints.
Most data within parenthesis in this document are US measurements.

2. T100 Power and Heat

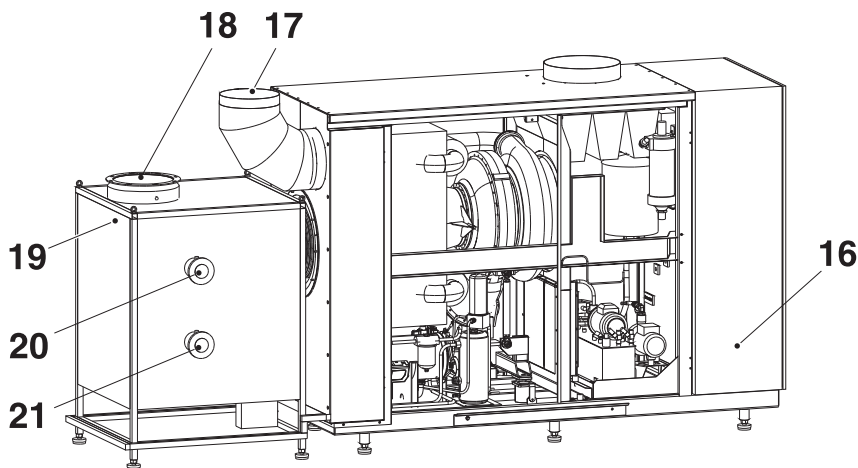

- 16. Power Module
- 17. Ventilation air outlet
- 18. Exhaust outlet
- 19. Heat exchanger
- 20. Water inlet
- 21. Hot water outlet

The T100 Power and Heat unit (T100 PH) is the T100 Power module combined with an exhaust gas heat exchanger. This combination allows the T100 to produce combined heat and power achieving very high overall efficiencies. The hot gases leaving the microturbine can be used to produce hot water. The total efficiency of the microturbine will in this way be maximized.

2.1 Product description

2.1.1 Main components for T100 PH

The main components for the Power and Heat unit are:

- Exhaust gas heat exchanger
- Power module

Exhaust gas heat exchanger

The exhaust gas heat exchanger is of gas-water counter-current flow type. The temperature of the exhaust gases is approx. 270°C (518°F), entering the exhaust gas heat exchanger. The thermal energy from the exhaust gases is transferred to the hot-water system by the exhaust gas heat exchanger. The outlet water temperature depends on the incoming water conditions, temperature and mass flow.

The exhaust gases leave the exhaust gas heat exchanger through an exhaust pipe and the subsequent chimney.

For information about the main components in the Power module, see section 1.1.1 Main components for T100 P.

1. Generator
2. Inlet air
3. Combustion chamber
4. Air to recuperator
5. Compressor
6. Turbine
7. Recuperator
8. Exhaust gases
9. Exhaust gas exchanger
10. Exhaust gas outlet
11. Hot water outlet
12. Water inlet

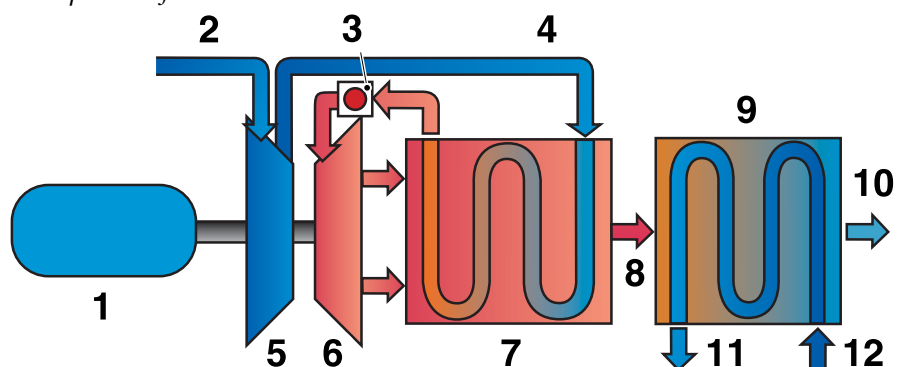

2.1.2 Auxiliary systems for T100 PH

For information about the auxiliary systems, see section 1.1.2 Auxiliary systems for T100 P.

2.1.3 Technical data for T100 PH

General identification

Type:	Microturbine
Manufacturer:	Turbec Spa, Italy
Model:	T100 PH
Application:	Combined Power and Heat
Usage:	Indoors (Option Outdoors)
Dimensions	
Width:	900 mm
Height:	1 810 mm
Length:	3 900 mm
Weight:	2 770 kg
Fuel:	Natural gas
Ambient inlet temperature:	-25°C to 40°C (-13°F to 104°F)
Ambient inlet humidity:	<100 %
Surrounding air temperature:	-10°C to 40°C (14°F to 104°F)
Surrounding humidity:	<100 %

For information about the technical data for the gas turbine, electrical data and gas requirements, see section 1.1.3 Technical data for T100 P.

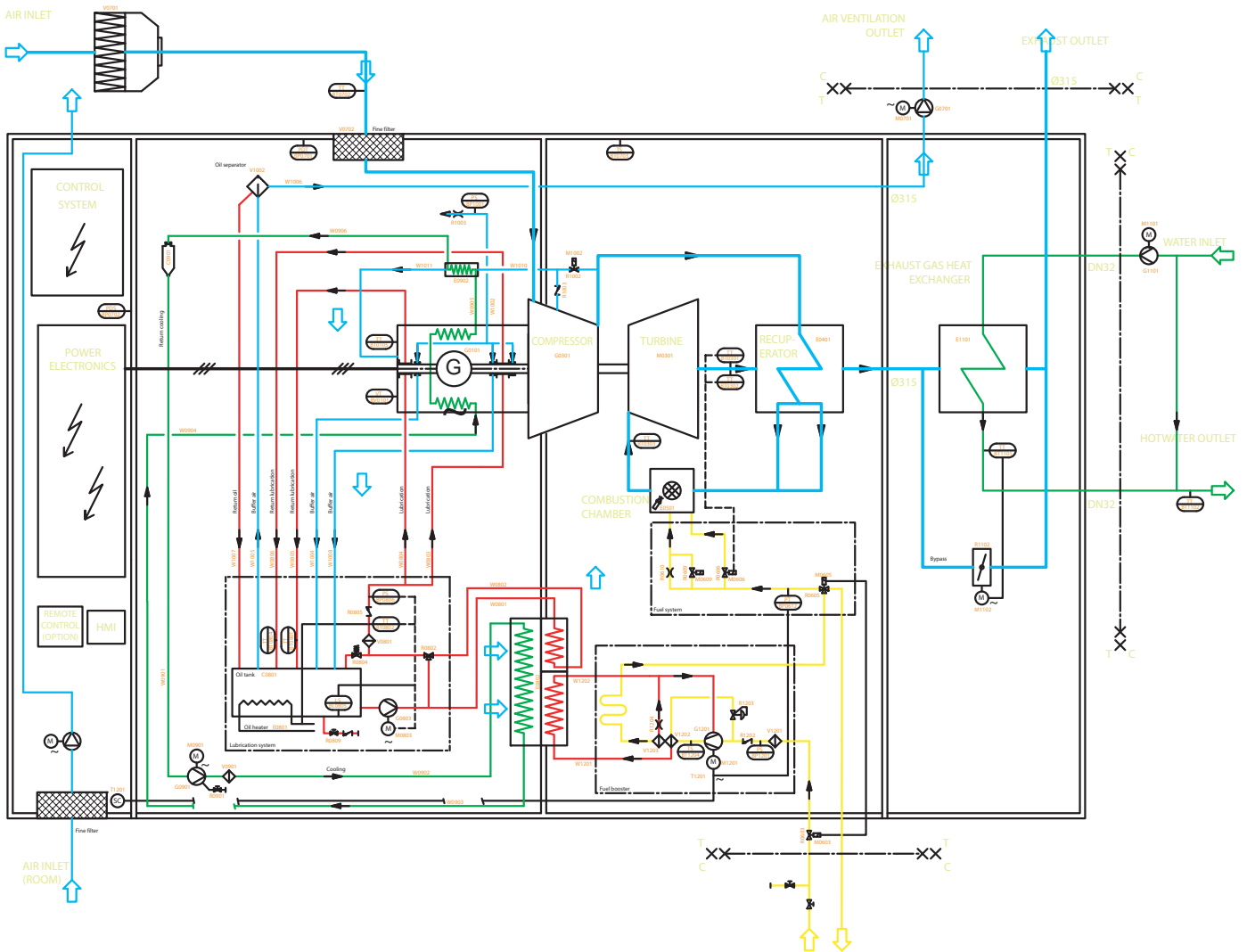
2.1.4 Principal diagram for T100 PH

2.2 Performance for T100 PH
Performance notes

The performance data includes the T100 auxiliary consumption powered by T100, i.e. cooling water pump, fuel compressor, oil pump, induced draft fan, buffer air pump. The data are based on the following conditions for new and clean equipment operating at ISO standard conditions:

Site elevation:	0 m above sea level
Ambient temperature:	15°C (59°F)
Relative humidity:	60%
Fuel type:	Natural gas
Data for LHV:	39 MJ/m ³ (1 047 Btu/scf)
Pressure drop to air inlet flange:	0 Pa (0 psi)
Pressure drop from exhaust gas flange:	0 Pa (0 psi)
Water inlet temperature:	50°C (122°F)
Water outlet temperature:	70°C (158°F)

2.2.1 Performance data

Fuel gas pressure:	Low pressure gas source (0.02 - 1.0 bar (g)) (0.3 - 14.5 psig)
Electrical output:	100 kW (±3)
Electrical efficiency:	30 % (±1)
Total efficiency:	80 % (±1)
Thermal output (hot water):	165 kW (±5) (563 000 Btu/h)
Fuel consumption:	333 kW (1 137 000 Btu/h)
Exhaust gas flow:	0.80 kg/s (6 350 lb/h)
Exhaust gas temperature:	70°C (158°F)
Noise level:	72,3 dBA at 1 meter (3.3 ft)

Nominal volumetric exhaust gas emissions at 15% O₂; 100% load; at 15°C air temperature:

NO _x :	< 6 ppm v = 12.8 mg/MJ fuel
CO:	< 6 ppm v = 7.2 mg/MJ fuel

Maximum volumetric exhaust gas emissions at 15% O₂; 100% load; at 15°C air temperature:

NO _x :	< 15 ppm v = 32 mg/MJ fuel
CO:	< 15 ppm v = 18 mg/MJ fuel

2.2.2 Air inlet temperature influence

The chart presents air inlet temperatures influence on T100 PH microturbine performance based on low pressure gas sources 0.02 bar (g) (0.3 psig).

Preliminary data. See additional information about electrical output and efficiency in section 1.2.2 Air inlet temperature influence.

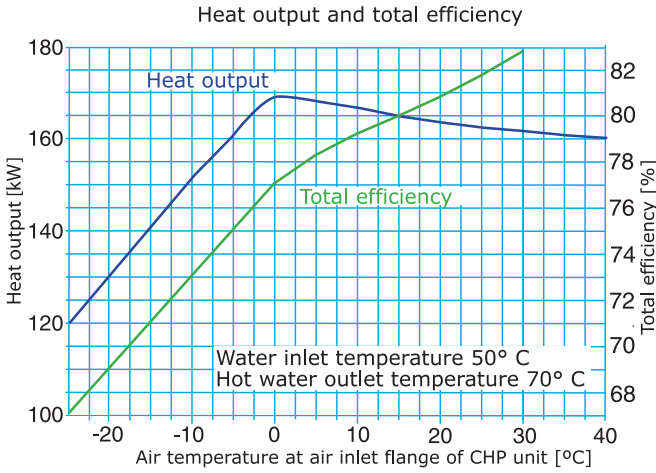

2.2.3 Corrections of performance

The thermal output statement in the diagram above depends on the inlet water temperature and on the difference between outlet and inlet water. A decrease (or increase) of 10°C (18°F) of the inlet water temperature will increase (or decrease) the thermal output by approximately 8 kW as shown in the picture. The efficiency correction factors are given in the same figure.

2.3 Scope of supply and Terminal points for T100 PH

2.3.1 Scope of supply

The delivery covers a complete Power and Heat unit, ready for installation at terminal points below. The main parts of the scope of supply are as follows:

- Microturbine unit including turbine, compressor, generator and recuperator
- Fuel system
- Closed cooling water system for generator and electrical system
- Closed lubrication system for gas turbine
- Hot water temperature sensor

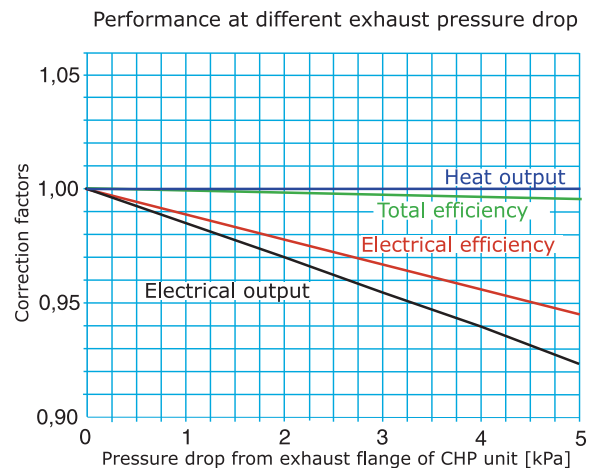
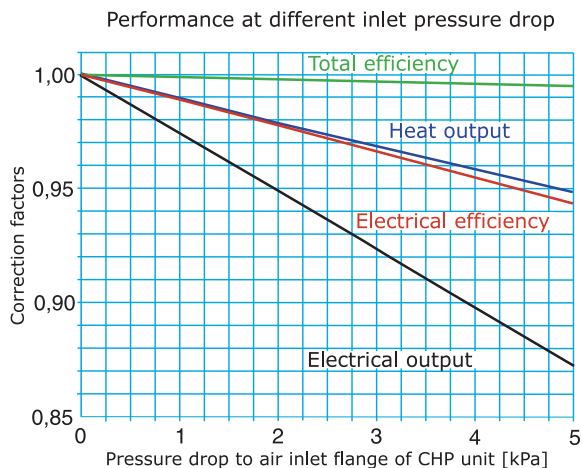
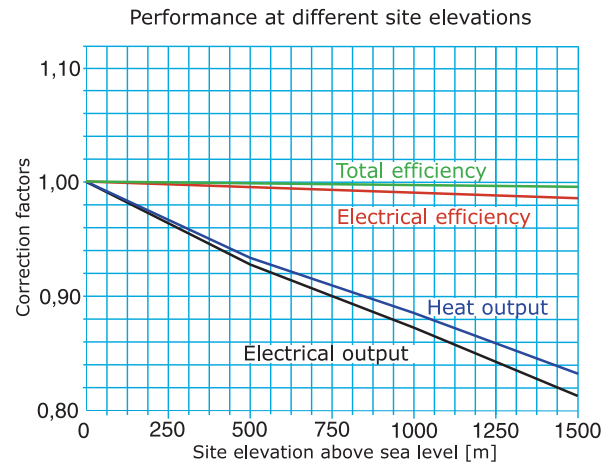
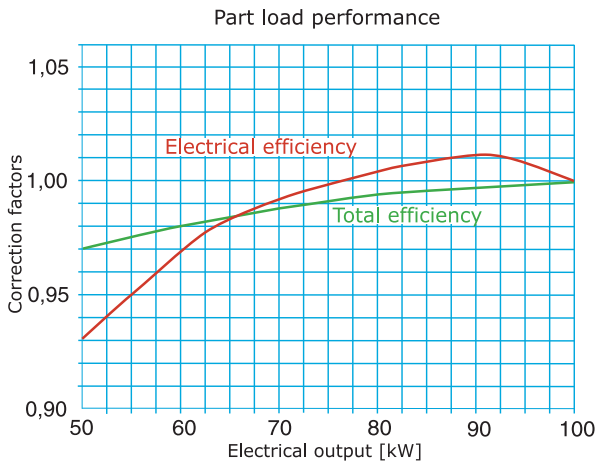
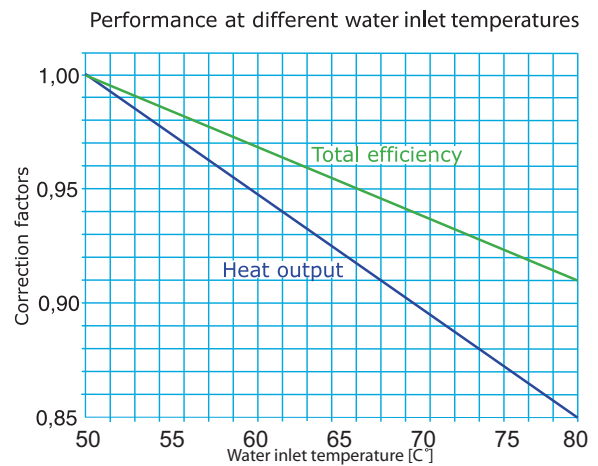

- Exhaust gas heat exchanger for hot water production
- Enclosure for insulation protection of heat and noise
- Induced draft fan for ventilation of the enclosure, delivered as a separate item
- Frequency and voltage converter for the supply of 400 VAC, 3 phase, 50 Hz
- High performance electrical output filtering
- Circuit breaker
- Starting system including synchronizer
- Control panel with digital LCD display
- RMC, Remote control system with modem
- Documentation:
 - Installation manual
 - Operator's manual
 - Maintenance manual
 - Electrical manual

2.3.2 Terminal points

The following terminal points apply to the scope of delivery of a Power and Heat unit of this proposal:

- Connection for air inlet, located at the T100 enclosure roof
- Exhaust gas outlet, located at the T100 enclosure roof
- Pre-filter (option)
- Fuel gas evacuation system outlet, located at the T100 enclosure wall
- Main inlet to gas fuel system, located at the T100 enclosure wall.
- Outlet connection of the ventilation air system, located at the T100 enclosure roof

- | | |
|--------------------------|-----------------------------------|
| A. Ventilation outlet | H. Grid cables |
| B. Water inlet | I. Electrical cables |
| C. Hot water outlet | J. Heat exchanger, drain |
| D. Fuel gas inlet | K. Heat exchanger, air evacuation |
| E. Fuel gas evacuation | L. Cable heat exchanger bypass |
| F. Prefiltered air inlet | M. Temp sensor, heat exchanger |
| G. Exhaust gas outlet | |

- Electrical connection at the T100 enclosure wall and connection to ventilation fan, hot water pump, hot water temperature, Ethernet cable or phone line for RMC connection.
- Connections for in- and outlet for the water on the exhaust gas heat exchanger, located at the T100 enclosure wall

2.4 Installation of T100 PH

2.4.1 Layout and terminal points

See drawing below.

2.4.2 Installation guidelines

For information about the combustion and ventilation air inlet pipe installation and the ventilation outlet installation, see section 1.4.2 Installation guidelines for T100 P.

Exhaust gas outlet installation

Type of connection:	Flange, 8 bolt holes 8.5 mm, Ø356 mm, (DIN 24154)
Material of connection:	Black steel
Max exhaust gas flow:	0.87 kg/s (1.92 lb/s)
Max temperature:	325°C (612°F)

Installation on site:

Pipe (Ø315 mm) to be installed from the T100 PH unit to a chimney, material according to national standard. Design the exhaust gas installation so the pressure drop is kept low. An expansion bellow has to be installed after the T100 PH interface. The chimney outlet has to be designed so that rain and snow cannot enter the T100 PH unit.

Hot water installation

Type of connection:	Flange, DN32, PN40 (DIN2635);
Min in water temperature:	50°C (122°F)
Max out water temperature:	150°C (302°F)
Max water pressure:	16 bar (g) (232 psig)

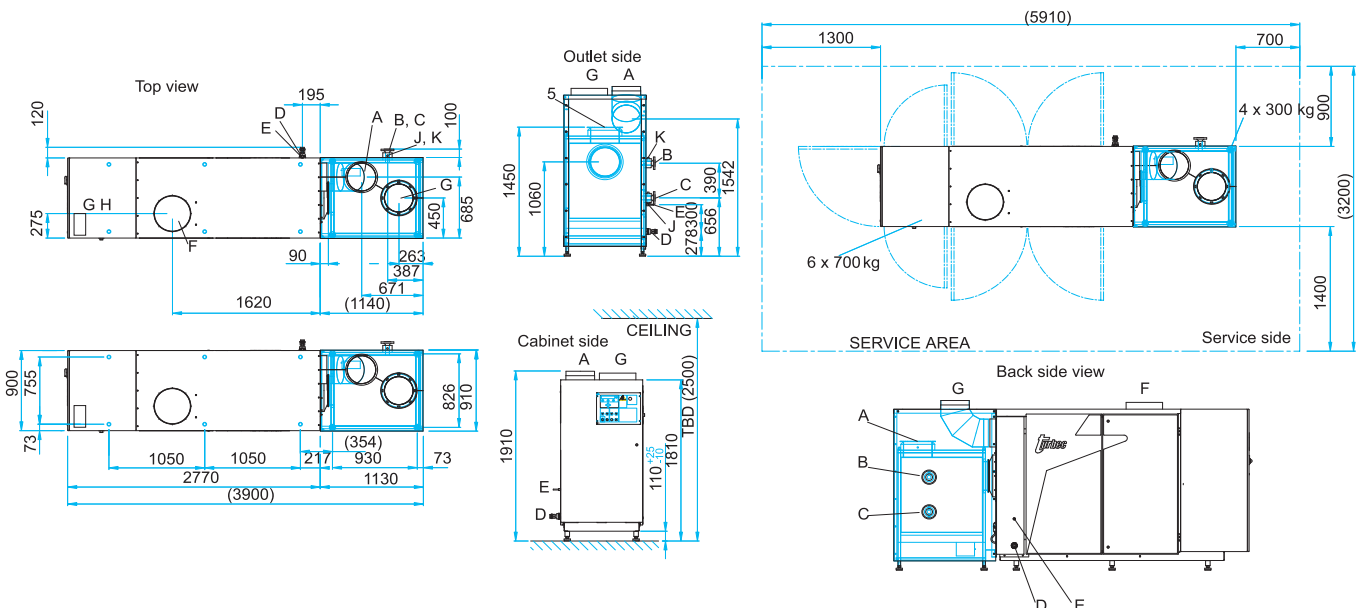

Nominal water flow:	2 litres/second (302°F)
Max allowed water flow:	4 litres/second (302°F)
Example:	
In water temperature:	50°C (122°F)
Out water temperature:	70°C (158°F)
Water flow:	2 l/s (4.24 ft ³ /min)
Pressure loss for water in exhaust gas heat exchanger:	33 kPa (4.8 psi)

Installation on site:

The T100 PH hot water circuit is connected to the existing system with one inlet pipe and one outlet pipe. A water-circulating pump is to be installed in the pipe upstream the T100 PH unit. The pump size is site specific. The default motor over-heat protection inside the T100 is dimensioned for 1.6-2.5 A motor current. Isolation valves and an inlet strainer are mandatory.

Electrical installation

Cable overview

This cable overview shows general information about what electrical cables are to be connected to the T100 for power generation output. It also shows general information about the most important signal cables for measuring and control. Exactly what signals are needed depends on the site and the functions being used. For further details, see the installation manual.

Cable	Connection point	Usage
Power cables	Electrical grid	Power generation
Water pump power	Water pump in water heat system	Feed a water pump within the ratings 1.6-2.5 A. For other ratings, a control signal is supplied
Water pump control	Water pump in water heat system	If the power connection can not be used, this control signal can be used
Water temperature	Temperature sensor	To control the T100 so the maximum water outlet temperature is within limits
Phone line	The national telecom or GSM (option)	Remote control system via modem

For information about the electrical installation, see section 1.4.2 *Installation guidelines for T100 P - Power grid connection, current protection, relay protection and emergency stop systems.*

Natural gas installation

For further information about natural gas installation, see section 1.4.3 *Natural gas installation.*

2.5 CE compliance

This equipment complies with the basic health and safety regulations of the European Economic Area (EEA). The T100 unit follows these directives:



- Machinery Directive 98/37/EC
- Noise Directive 2000/14/EC
- Electromagnetic Compatibility Directive 2004/108/EC
- Low Voltage Directive 2008/95/EC

2.6 Maintenance concept

The maintenance concept for the Turbec T100 PH is the same as for the T100 P. *For information about this, see section 1.6 Maintenance concept.*

2.7 Operation of T100 PH

Start

The starting system is fully automatic and can be engaged by a push button on the local control panel or via the remote control system, an external Building Management System (BMS), a MODBUS communication or automatically via an external weekly scheduler. The start up sequence includes starting, evacuation, ventilation and synchronization to the grid.

Normal start-up procedure will bring a cold T100 microturbine into 80% load in 10 minutes, and 100% load in 20 minutes. During start up the generator operates in motoring mode, using electrical power from the grid. After 60 seconds of ventilation the combustor is ignited, the generator speeds up and the power generation is started. The enclosure, the engine and the exhaust pipe are completely purged before ignition.

Restart time after shutdown will be less than 5 minutes, provided that the engine is still warm. The T100 is equipped with a function for automatic restart, activated when the stop was caused by external disturbances. A short interruption or disturbance on the electrical grid will not cause a T100 stop. Instead it will disconnect from the grid by opening the main contactor, keep the T100 running supplying the T100 auxiliaries and reconnect when the grid returns.

Operating Mode

The T100 microturbine operates mainly on standard speed regulation, which results in a high efficiency in part load operation.

Control System

The T100 unit can be controlled in seven ways:

- Locally by the Operators panel
- Through hard-wired BMS
- Through a pc with a web browser connected to the T100 unit via Ethernet cable

- Through a pc with a web browser connected via a telephone modem (normal or GSM(option)) to the T100 control system
- Via Modbus interface, RS232
- Automatically with a weekly scheduler (option), allow starts and stops according to a pre-defined schedule
- Depending on externally measured data, such as water or air temperatures or electrical power (the option load following)

Examples of operational control commands:

- Start and Stop of the machine, including a manual emergency stop
- Change set points for electrical active and reactive power demand
- Do a fault reset

Examples of data that can be monitored through the control system:

- Operational mode: stopped, starting, running, and stopping
- Measured data: electrical power output, (net electrical power as option), produced electricity, running hours, etc.
- Warnings and faults with description

3. Options

3.1.1 External pre filter (mandatory indoors)

An external ambient filter is needed for the Turbec T100 indoor installation. It is available as an option from Turbec, but it can be purchased from a local supplier if the requirements are observed:

Filter type: G3, (EU3)
 Min air flow at 15°C (59°F): 1.69 kg/s (=1.38 m³/s);
 3.73 lb/s (=48.7 ft³/s)

Max pressure drop for a clean filter: < 50 Pa (0.20" W.C.)
 Max pressure drop for a worn filter: < 190 Pa (0.76" W.C.)

Make sure the filter type preferred uses an intake screen, e. g. use two standard size cases with the dimensions: 610 x 610 mm (2.00 x 2.00 ft).

The pipe shall be fitted with 50 mm (2") condense insulation.

The pre-filter is connected to a twisted galvanized tube with Ø400 mm, which directs the combustion air to the inlet of the T100 microturbine.

See the figure in section 1.4.2 Installation guidelines.

3.1.2 Outdoor installation

An outdoor module makes it possible to install the machine on an outdoor site. The outdoor module consists of two separate parts:

- Outdoor air intake module
- Outdoor outlet module

The outdoor air intake module includes a coarse pre filter, and a silencer. The module is installed on top of the Power module.

The outdoor outlet module includes an induced draft fan and a chimney for exhaust gas and air outlet. The module is installed on top of the heat exchanger, if the machine is equipped with one. Otherwise, the module is installed on the exhaust pipe module.

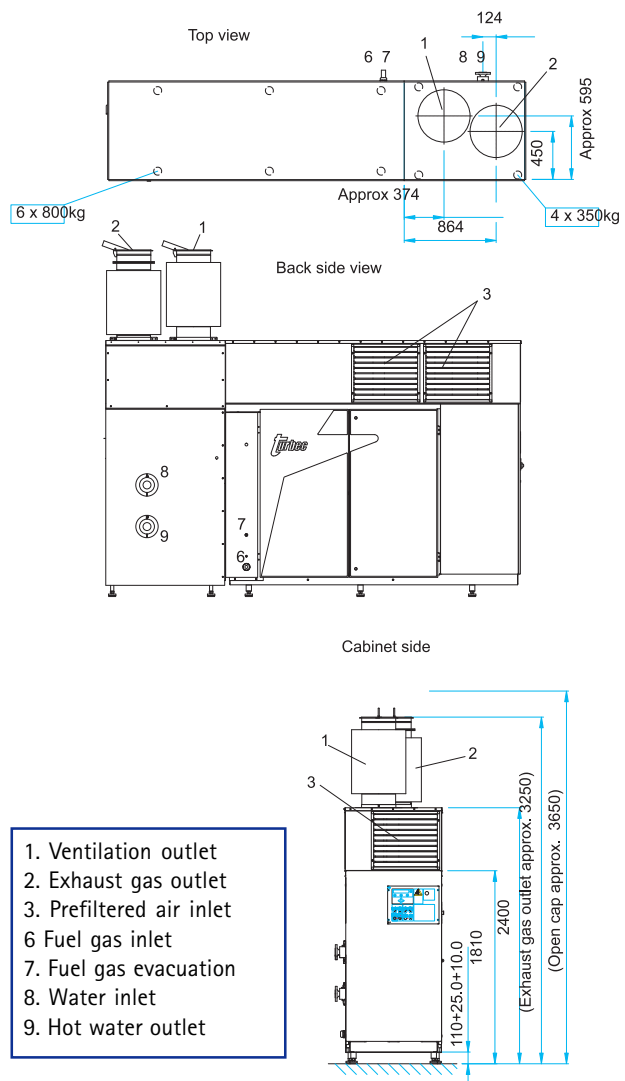

Dimensions of the outdoor module:
 Width: 900 mm
 Height: max 2 410 mm
 Length: 3 900 mm
 Weight: 3 100 kg
 Min height with chimneys: 3 650 mm
 Ambient inlet temperature: -10°C to 40°C (14°F to 104°F)

Scope of supply:

The main parts of the scope of supply are the same as for the Power Module, *see section 3.1.1 Scope of supply*, except for the induced draft fan for ventilation, which is enclosed in the outdoor module.

The outdoor installation also includes:

- Outdoor air intake module
- Outdoor outlet module

Terminal points

The outdoor module simplify T100 interconnections as a number of terminal points are considerably reduced. The following terminal points apply for an outdoor installation:

- Fuel gas inlet, located at the T100 enclosure wall
- Electrical connection at the T100 enclosure wall and connection to ventilation fan, hot water pump, hot water temperature, network cable or phone line for modem connection.

Additional terminal points for Power and Heat unit:

Connections for in- and outlet for the water on the exhaust gas heat exchanger, located at the T100 enclosure wall. If there is a risk of freeze, protect the water system by isolated water pipes and have the system prepared so it easily can be drained in case of long time inactivity. Connection to exhaust gas outlet located at the T100 enclosure roof.

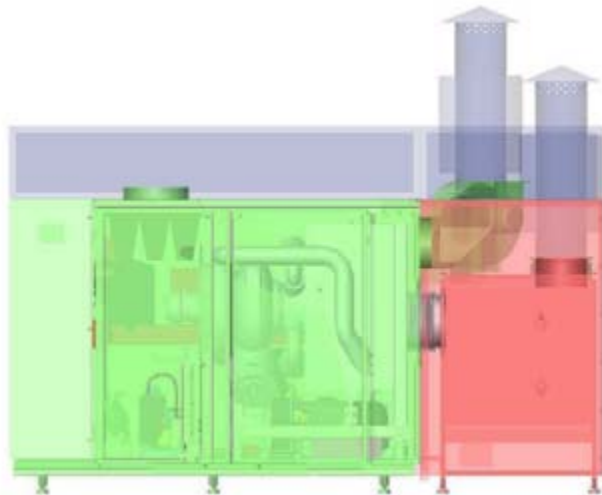
3.1.3 By-pass of heat exchanger

Turbec T100 PH's heat exchanger by-pass solution allows the electrical power to be regulated independently of heat production. This system makes it possible to produce full electrical output, even if the demand for heat is very low.

3.1.4 Load following

Load following makes it possible to only produce the amount of electricity needed at the site for consumption. The export of electricity to the net is minimized when there is a small load in the facility. There will be no compromise on the values for capacity, efficiency, low emissions or the

effect response. The number of re-starts per 24-hours is minimized by the way the load-following function is configured. In this way the costs for added fuel and electricity at re-start will be minimized as well. When using load following use it at a multiple T100 installation, a T100 site controller with start/stop and a set power reference signals to the individual T100 units. The power meter at the site/utility grid interconnection can be supplied by Turbec. In principle, all type of power meters providing a 0-20 mA output can be used.

3.1.5 Removal of fuel booster

It is possible to remove the gas compressor from the T100 P unit if necessary. If the natural gas compressor is between 6 -7 bar (g) there is no need for a gas compressor.

3.1.6 Additional relay protection

The Turbec T100 microturbine can be fitted with an electrical relay protection system. The system is additional, and is not required for the running of the T100. The protection system automatically disconnects the power feed to the grid if a time limit is exceeded after a measured breach of the voltage or frequency limits. The demand for additional protection is regulated by national or local standards. For example, a G59 relay protection unit is needed in UK and the DVI604 in Italy.

3.1.7 Log file decoder

Its function is to decode and work with start, crash and log files. This feature will aid qualified fault tracing and analysis.

3.1.8 GSM Modem

A standard modem is supplied. If it is not possible to connect the modem to a phone line it is possible to equip the T100 with a GSM modem as an option.

3.1.9 Weekly scheduler

The T100 can be automatically started and stopped by using this optional function. By using a WWW interface, the start and stop schedule, can easily be programmed by the user to meet a week running schedule.

3.1.10 Alternative fuels

The T100 can be operated with alternative fuel, such as biogas and diesel. Please contact Turbec for further information.



Turbec Spa, Via Statale, 20/A - 44040 Corporeno (FE) Italy
 Phone: +39 051683573 Fax: +39 0516830348
 E-mail: info@turbec.com Site: www.turbec.com

Copyright © 2009 Turbec Spa

All rights reserved. No parts of this document may be reproduced or copied in any form or by any means without written permission from Turbec Spa. The material and data in this document may be changed without further notice, reservations for misprints.

Most data within parenthesis in this document are US measurements.