

External coarse pre filter kit

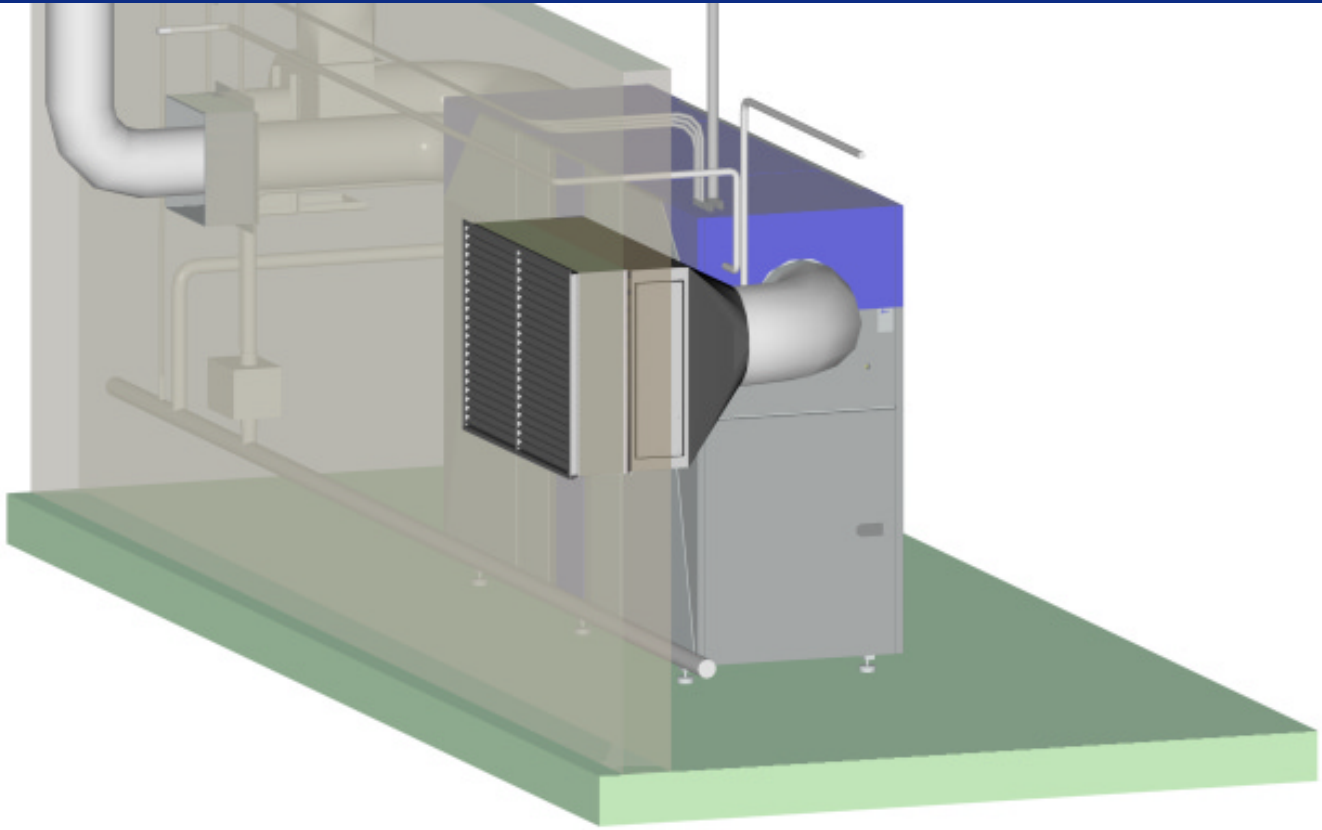

An external ambient filter is needed for the Turbec T100 installation. The kit includes a galvanized filter frame and two replaceable filter cassettes. The pre-filter is available as an option from Turbec, but the pre-filter can also be provided from other suppliers if the following requirements are observed.

Description

The Turbec T100 needs particle free combustion air to execute its high performance. The main function of the product is to filter out air particles before they reach the microturbine. The coarse pre filter kit is mounted in a galvanized frame. The depth of the frame is adapted to suit most vertical walls. A grille protects the outdoor side of the filter cassettes from foreign objects. A hatch on the indoor side covers the filter cassettes. By removing the hatch, the worn filter cassettes are free for exchange. The time between the filter exchanges are influenced by the operating time and the environmental conditions, so the exchange schedule may vary from installation to installation.

The coarse pre filter is connected to a twisted galvanized tube with $\text{Ø} 400$ mm which carries the combustion air to the inlet of T100 microturbine.

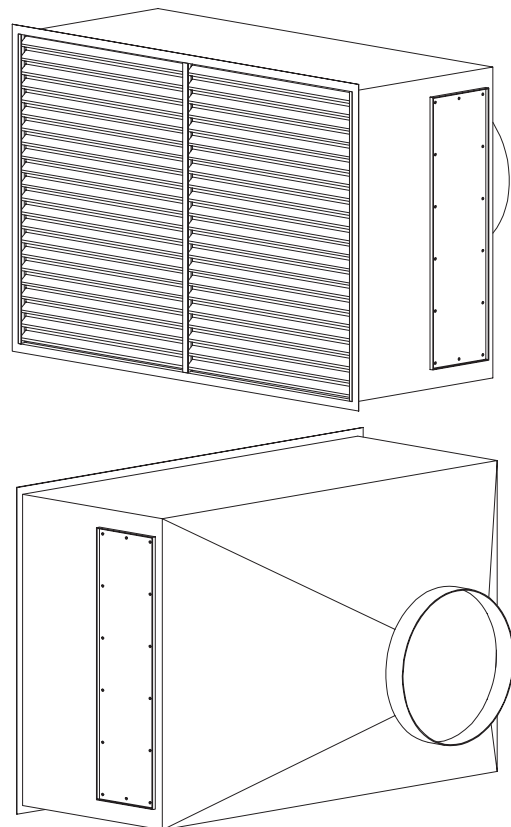

Technical data

Filter type:	G3, (EU3)
Min air flow at 15°C:	1.69 kg/s (=1.38 m ³ /s)
Max pressure drop for a clean filter:	< 50 Pa
Max pressure drop for a worn filter:	< 190 Pa

Make sure the filter type preferred uses an intake screen, E. g. use two standard size cases with the dimensions: 610 x 610 mm.

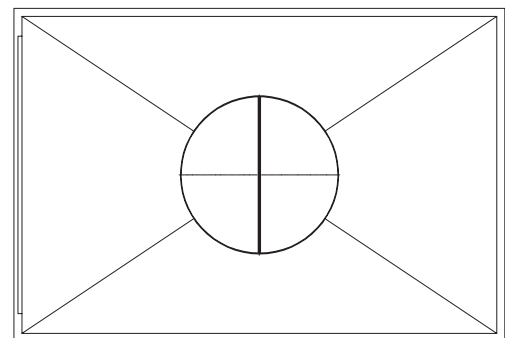
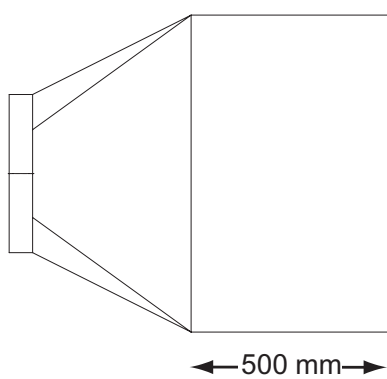
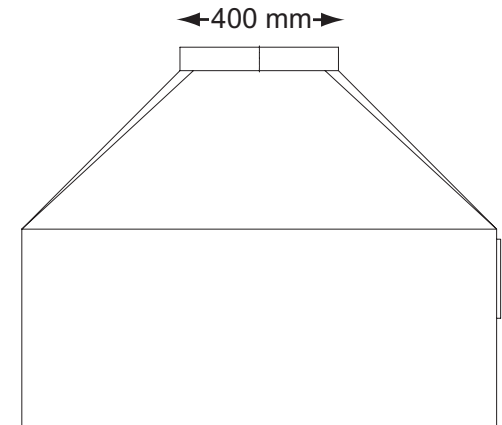
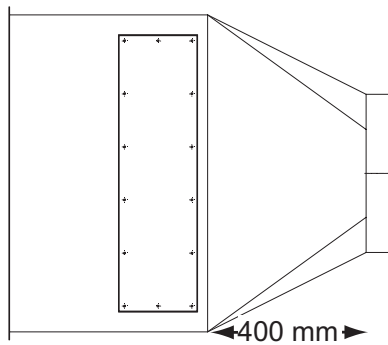
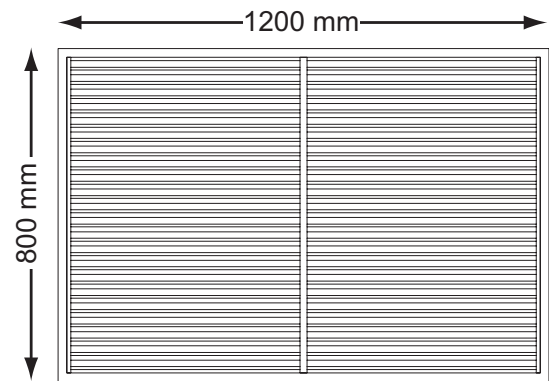

D 11075 Technical data sheet. Version 1.0



Version 4.0 Copyright © 2001 Turbec AB
 All rights reserved. No parts of this document may be reproduced or copied in any form or by any means without written permission from Turbec AB. The material and data in this document may be changed without further notice, reservations for misprints.

This equipment complies with the basic health and safety regulations of the European Economic Area (EEA)

